



EXTERNAL CONTROL MODULE DATA SHEET

Description:

The External Control Module simplifies the connection of an external motor drive to the Dynamo motor by providing the user with a standard set of hall signals, numerous encoder options, and a high current connector for the motor phase windings. The module is compatible with external motor drives using a 10 to 48Vdc power supply. The External Control Module provides a standard system for rotor position sensing required by many brushless motor drives. Three hall sensors spaced 120 electrical degrees apart, sense a magnetic disk, which is synchronized to the rotor of the motor. The hall signals can be used to provide inexpensive speed feedback to the motor drive, or for more precise control a wide array of integral two channel quadrature encoder options are available. The quadrature nature of an encoder allows the user to determine the direction of motor rotation as well as speed.

Environment:

The NT Dynamo uses a TENV (totally enclosed non-ventilated) non-gasket construction. Installation and operating conditions should not exceed the recommended values for humidity and temperature. Contact the Hurst engineering department regarding any special installation issues you may have regarding vapors, oils or dust.

Storage Temp.: 32-158°F (0-70°C) Humidity: 90% Max. Non-condensing Operating Temp.: 32-104°F (0-40°C)

Power:

Power to the motor windings is via the 4-pin connector. A regulated DC supply must be provided for the encoder and hall devices. Observe the correct polarity when making these connections. For maximum flexibility and noise immunity, the hall and encoder power supplies are separated. Excessive amounts of voltage ripple can cause shortened product life.

Motor Windings:

Minimum DC Voltage: 10Vdc

Maximum DC Voltage: 48Vdc

Encoder:

Minimum DC Voltage: 4.75Vdc

Maximum DC Voltage: 5.25Vdc

Halls:

Minimum DC Voltage: 4.2Vdc

Maximum DC Voltage: 24Vdc

Connector	Pin #	Function	Mating Connector	Mating Terminal	Recommended Wire Size	Cable Length
Power	1	Phase C	Molex 39-01-2040	Molex 39-00-0039	22 AWG	30 ft. Max ¹
	2	Phase B				
	3	Phase A				
	4	Gnd				
Hall	1	V _s	Molex 50-57-9408	Molex 16-02-0103	22 AWG	30 ft. Max ¹
	2	V _{s(RTN)}				
	3	Hall S2				
	4	Hall S1				
	5	Hall S3				
	6	N/A				
	7	N/A				
	8	N/A				
Encoder	1	+5V _s	FCI 65846-016	FCI 48236-000	22 AWG	30 ft. Max ¹
	2	Encoder A				
	3	Encoder B				
	4	Index				
	5	+5V _{s(RTN)}				
	6	Encoder /A				
	7	Encoder /B				
	8	/Index				

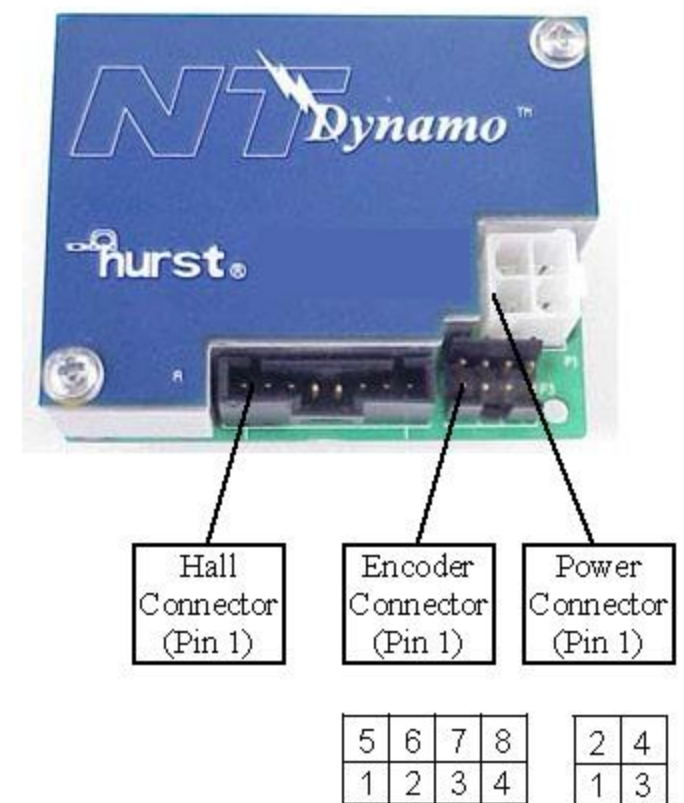

Notes

- 1) Longer cable runs may require a larger wire size to maintain the correct input voltage level and a signal amplifier / conditioner to avoid erroneous signal values. For cable runs longer than 3 ft, shielded wire is recommended.

Commutation:

The External Module Control uses three Hall effect devices to provide the commutation signals. The Hall effect devices sense the magnet field produced by a magnetized wheel attached to the motor shaft and produce three square wave signals phased 120° apart (See Figure 1). These three signals are used by the brushless controls to generate current to the proper motor phases.

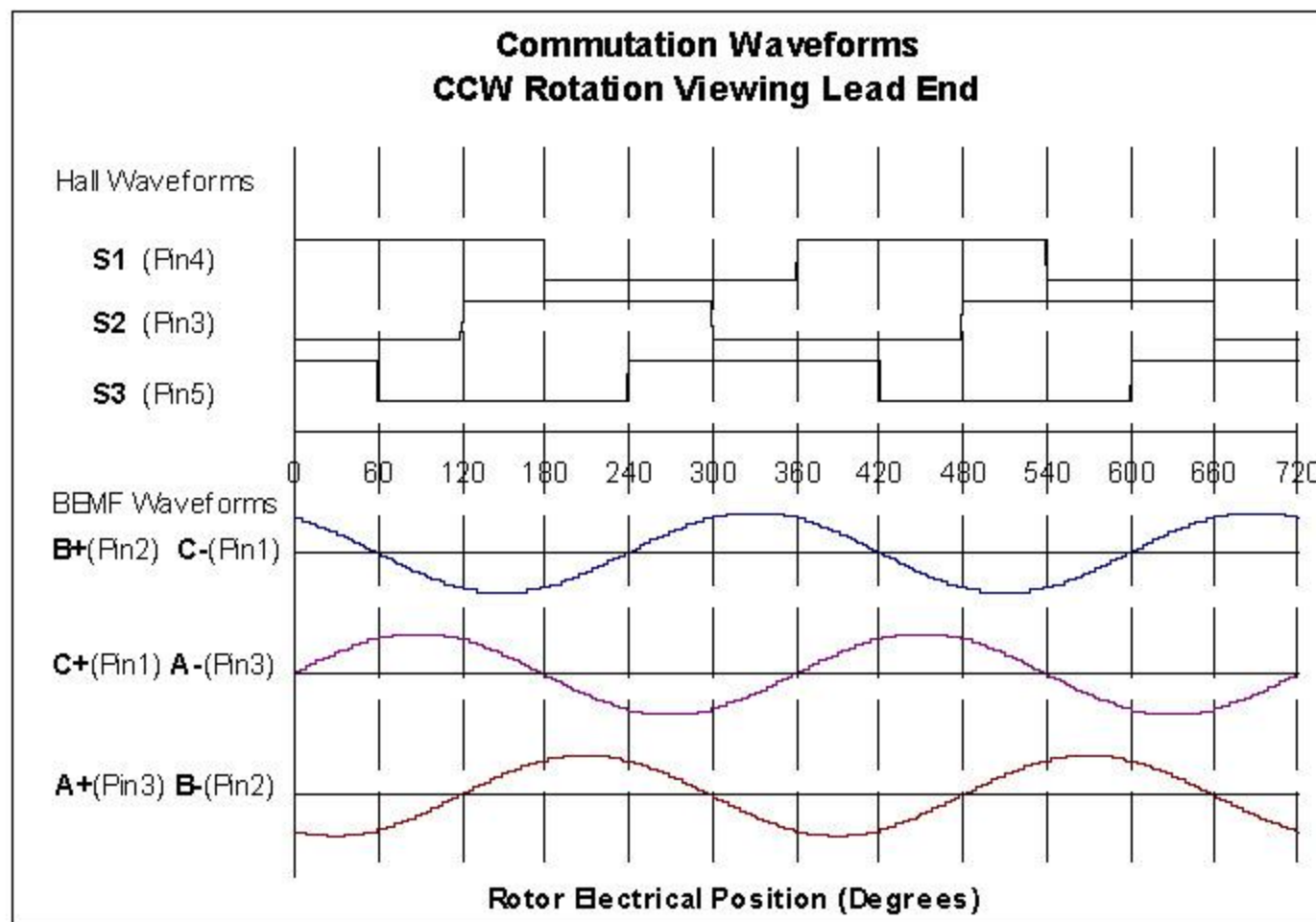

Figure 1

Encoder:

The control module may contain an optional shaft mounted optical encoder. The encoder outputs two channel quadrature signals (90° out of phase) with complements. Speed and direction can be determined by using the quadrature signals (See figure 2). Encoder may also contain an optional index pulse with a complement. The index pulse is generated once per revolution and the width is typically 90 electrical degrees. The encoder outputs can be used by an external drive to close the speed loop.

Encoder Type	Incremental	
Supply Voltage	+5Vdc ±10%	See 'Power Section'
Supply Current w/o index	20 mA typical	
Supply Current w/ index	90 mA typical	
Output Format	Two Channel Quadrature with complements, also optional index pulse	
Output Type	Square Wave	
Frequency Response	20 kHz	(Velocity (rpm) X N)/60 N= Number of Counts per Revolution

CCW Direction viewed from Lead End

Figure 1

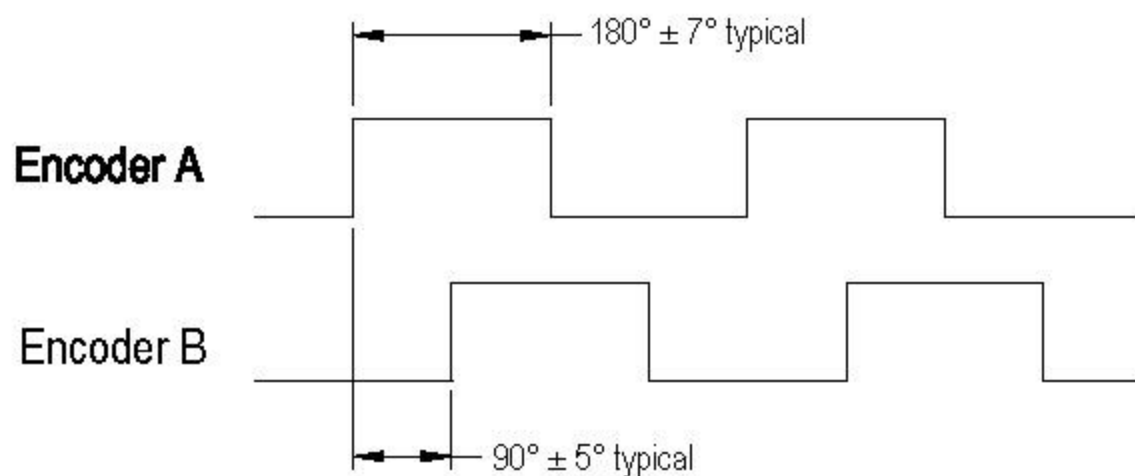

**For More Information Visit The Website at www.hurst-motors.com or
Contact Hurst Engineering at 812-385-2564**