

STEPPING MOTOR FAMILY

Series 57mm (SAS) Geared Stepping Motor



Step Angle:	7.5° & 15°
Position Accuracy:	+/- 5% max.
Number of Phases:	4 phase bifilar
Insulation Class:	Class A (105°C)
Lead Wire:	6 leads 24AWG (approx. 9 inches [228.6 mm])
Operation Ambient Temp:	-10°C to +40°C (approx.)
Shaft Bearing:	Sleeve Bearing
Gear Unit:	Zinc Die Cast - AGMA 7 Standards with hardened steel gears
Note: Typical data subject to change without notification	

The geared SAS Stepping Motors have a step angle range of 0.0125° to 7.5° and output speeds at 200 p/s from 0.42 to 250.0 RPM.

All gears are hobbed to AGMA 7 quality. Pinions are extruded from a special steel with a modified long addendum tooth form to provide higher strength. Pinions are held to the same AGMA 7 quality level as the gears. Both pinion and gear teeth are case hardened for wear resistance and rotate upon hardened and ground steel studs.

Notes:

- Sleeve bearings are standard. Ball bearings may be specified.

Model	Part Number	Reduction	Step Angle (degrees)	Rated Torque @ 200 p/s (oz-in)	Rated Torque @ 200 p/s (mN-m)	Output Speed (RPM)	Maximum gear train loading	Input Power (watts)	Nominal Voltage (Vdc)	Winding Resistance (ohms)	Weight (oz)	Weight (g)
SAS	4004-001	600	0.0125	200	1412.3	0.42	X	8	12	36	16	453.6
SAS	4004-002	300	0.025	200	1412.3	0.83	X	8	12	36	16	453.6
SAS	4004-021	300	0.025	200	1412.3	0.83		8	6		16	453.6
SAS	4004-004	150	0.05	185	1306.4	1.67		8	12	36	16	453.6
SAS	4004-006	75	0.1	162	1144	3.33	X	8	12	36	16	453.6
SAS	4004-027	75	0.1	162	1144	3.33		8	24		16	453.6
SAS	4004-009	37.5	0.2	126	889.8	6.67		8	12	36	16	453.6
SAS	4024-003	37.5	0.2	126	889.8	6.67		8	12	36	16	453.6
SAS	4004-010	30	0.25	101	713.2	8.33		8	12	36	16	453.6
SAS	4004-026	30	0.25	101	713.2	8.33		8	6		16	453.6
SAS	4004-012	15	0.5	54	381.3	16.67		8	12	36	16	453.6
SAS	4004-014	10	0.75	36	254.2	25		8	12	36	16	453.6
SAS	4004-025	10	0.75	36	254.2	25		8	24		16	453.6
SAS	4004-019	2	3.75	7.2	50.8	125		8	12	36	16	453.6

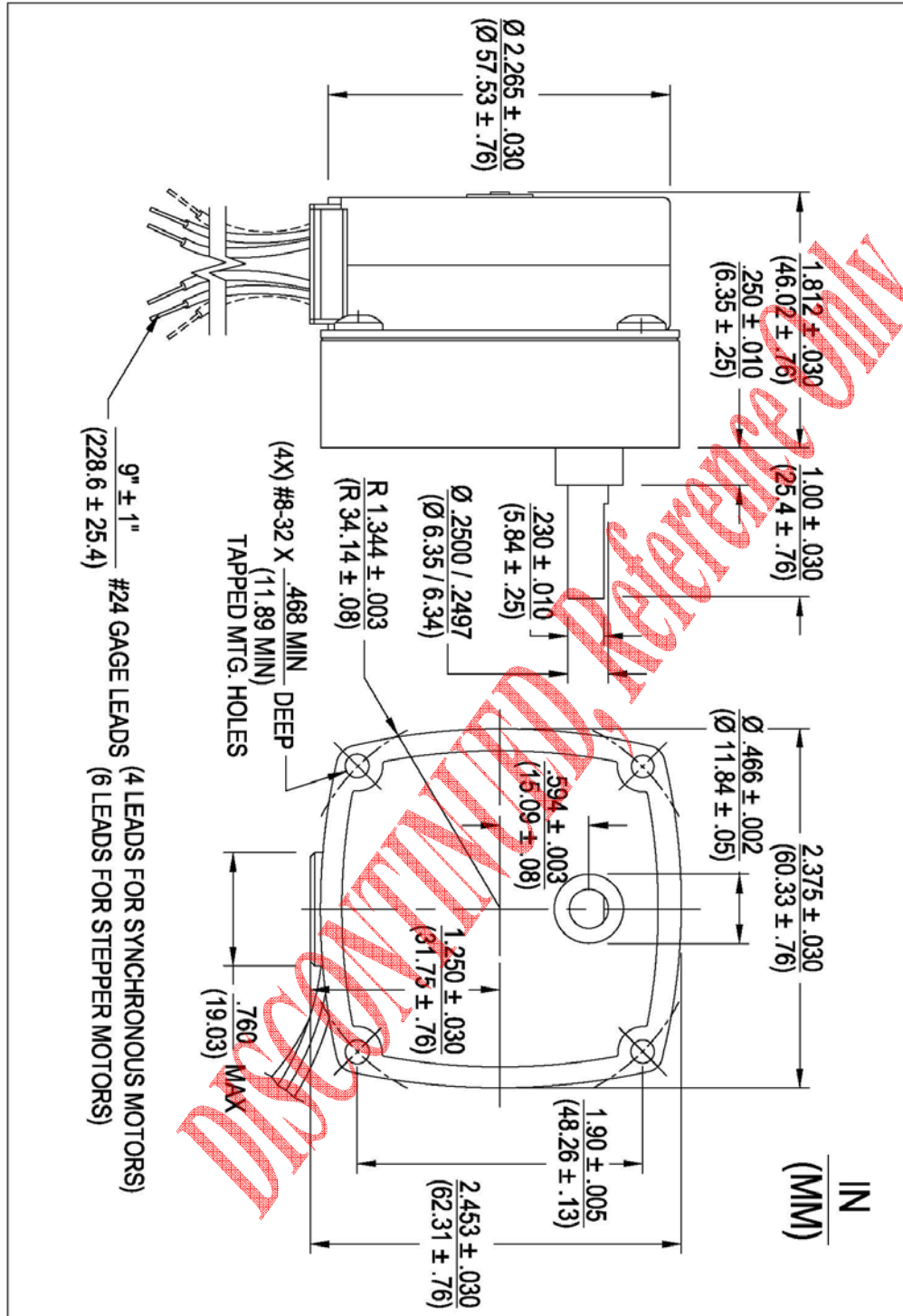

**MODELS SAS 4003-002 and SAS 4019-001
UNIPOLAR L/R DRIVE**

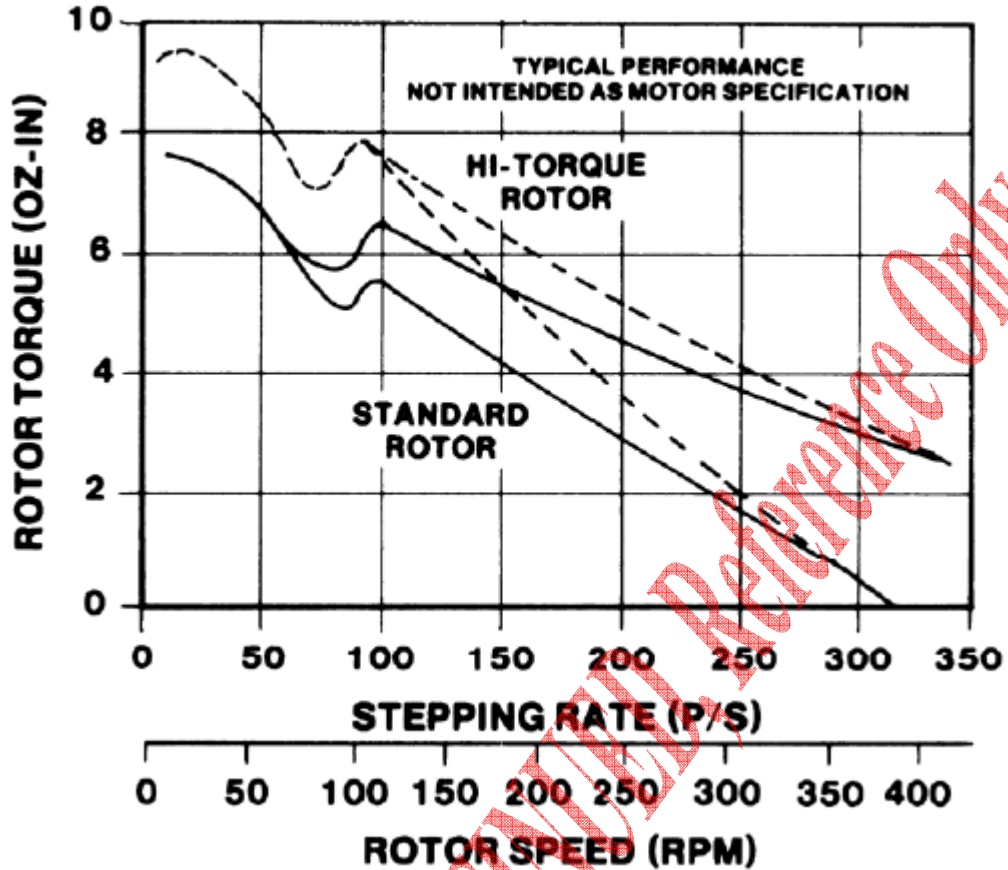

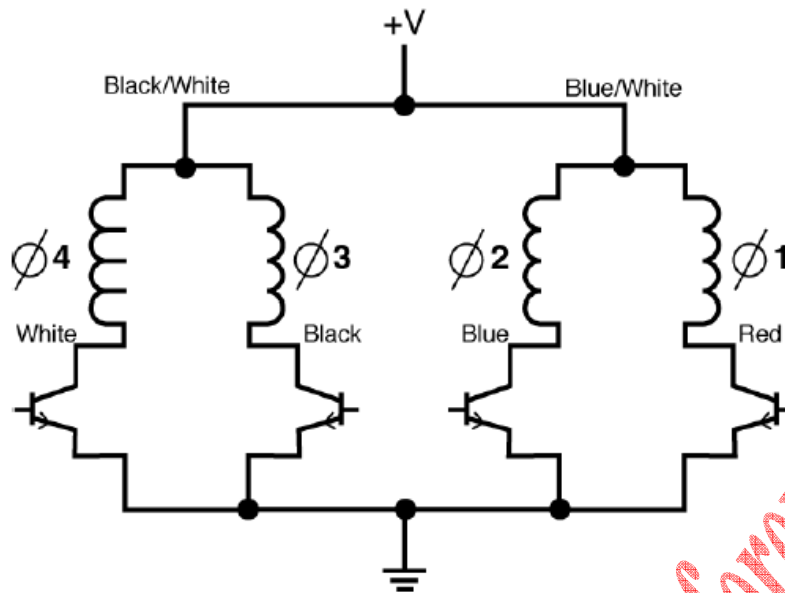

	Ø4 White	Ø3 Black	Ø2 Blue	Ø1 Red	
CCW ROTATION ↑	1	0	1	0	↓ CW ROTATION
	1	0	0	1	
	0	1	0	1	
	0	1	1	0	

1 = ON, 0 = OFF

SWITCHING SEQUENCE