

HYBRID STEPPER MOTOR FAMILY

Series H17 Hybrid Stepper Motor

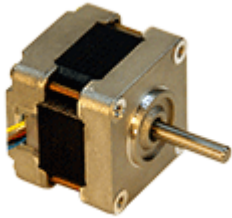

Mounting Flange:	NEMA 17
Step angle:	1.8°
Steps per Revolution:	200
Positional Accuracy:	+ 5% max.
Number of Phases:	4 (unipolar)*
Temperature Rise:	70°C max
Insulation Resistance:	100M ohms at 500VDC for 1 minute
Dielectric Strength:	500VAC for 1 minute
Insulation Class:	Class B
Number of lead wires:	6 *
Lead wire:	UL3265 AWG#26
Operation Ambient Temp:	-10°C ~ +50°C
Radial Play:	0.03 mm max at 0.4 kg load
Axial Play:	0.08 mm max at 0.5 kg load
* Contact Hurst for other lead or phase configurations	

Unipolar Drives

Motor phase winding current is switched in only one direction (typically to ground).

- Simple low cost drive circuit
- Requires center tap winding
- Low Output Torque
- 6 & 8 lead motors

Bipolar Drives

Motor phase winding current is switched in both directions.

- Higher cost drive circuit
- Higher Output Torque
 - Approximately 1.4 X Unipolar Drive
 - 4, 6, & 8 lead motors
 - 8 Lead Motors are more efficient when used with a bipolar drive.

Example: H 17 032 4 34

	Motor Family	Frame Size	Phase Voltage	Phase	Length
Options	Hybrid Stepper	17=17mm	032=3.2VDC	4=4 Phase Unipolar	31=31mm
			040=4.0VDC	2=2 Phase Bi-polar	34=34mm
			045=4.5VDC		40=40mm
			120=12.0VDC		

Model	Part Number	Step Angle (deg.)	Holding Torque (oz-in)	Holding Torque (mN-m)	Detent Torque (oz-in)	Detent Torque (mN-m)	Input Power (watts)	Nominal Voltage (Vdc)	Winding Res. (ohms)	Rated Ind. (mH)	Rotor Inertia (oz-in ²)	Rotor Inertia (g-cm ²)	Case Length (in)	Case Length (mm)	Weight (oz)	Weight (g)
H17	H17032434	1.8	15.3	108	1.25	8.8	7.68	3.2	2.7	2.3	0.109	19.9	1.34	34	7	198.4
H17	H17040434	1.8	15.3	108	1.25	8.8	8	4	4	4.2	0.109	19.9	1.34	34	7	198.4
H17	H17040440	1.8	25	176.5	1.39	9.8	8	4	4	3.7	0.164	30	1.575	40	8.8	249.5
H17	H17045431	1.8	13.9	98.2	1	7.1	4.5	4.5	9	6	0.087	15.9	1.22	31	6.3	178.6
H17	H17120434	1.8	15.3	108	1.25	8.8	3.84	12	75	85	0.109	19.9	1.34	34	7	198.4
H17	H17120440	1.8	25	176.5	1.39	9.8	9.6	12	30	33	0.164	30	1.575	40	8.8	249.5

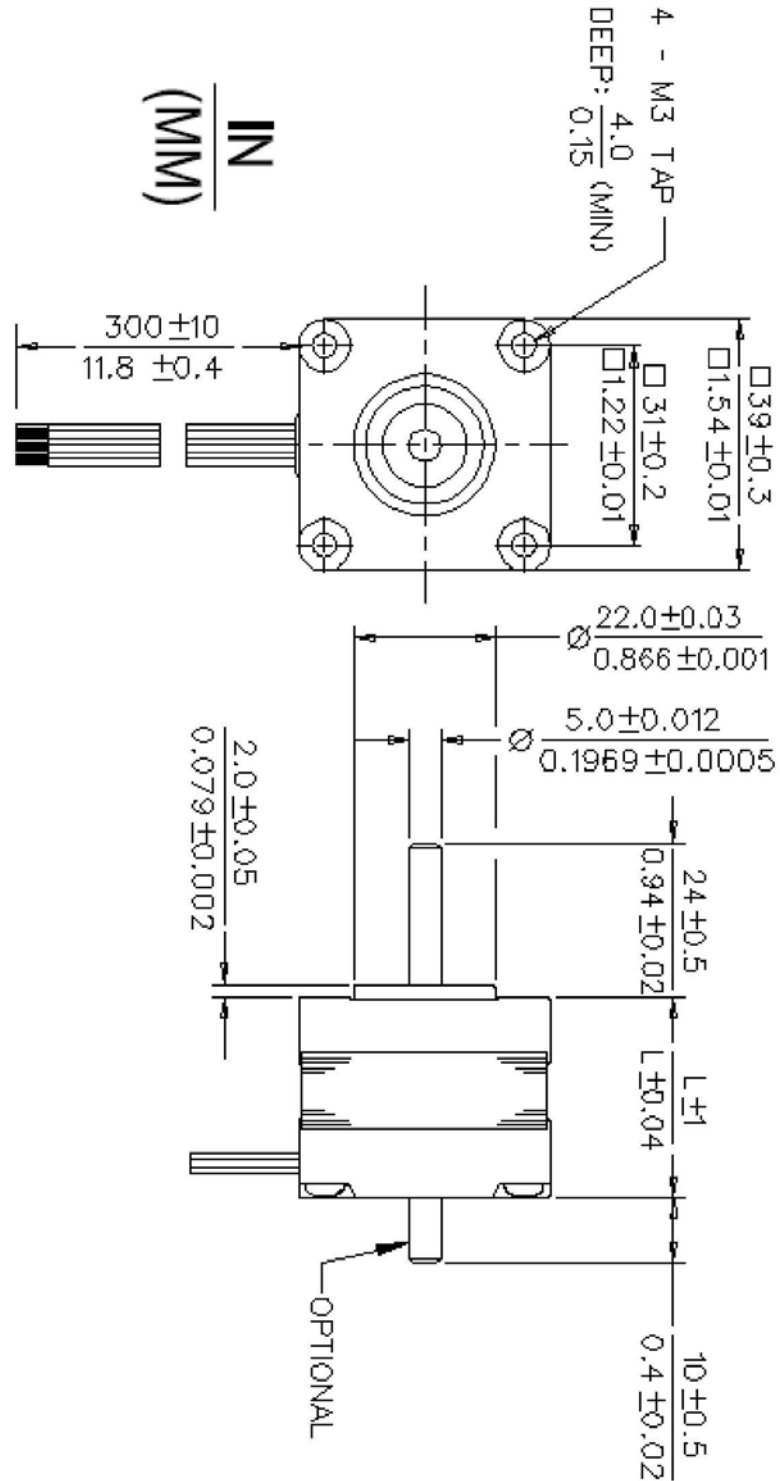

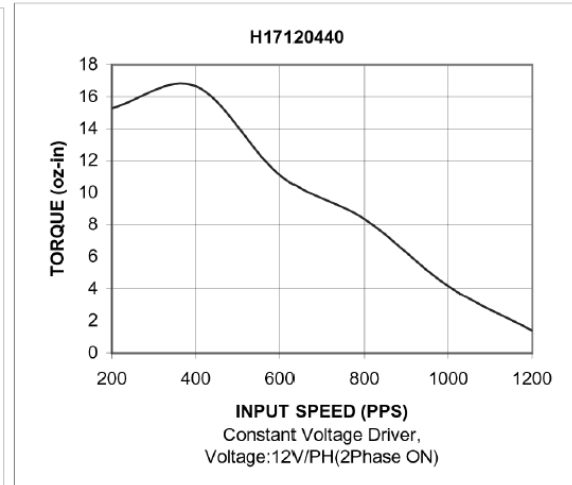
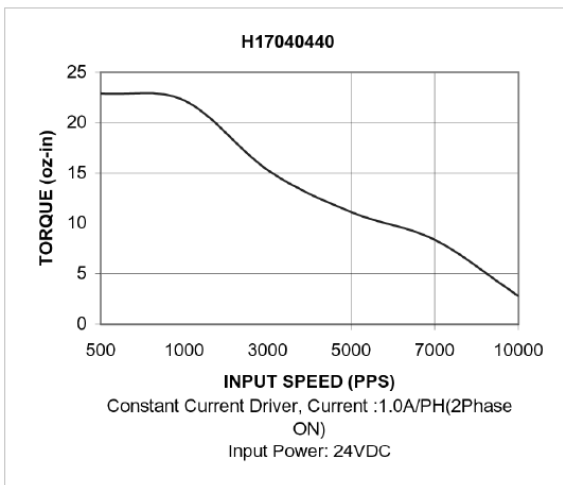
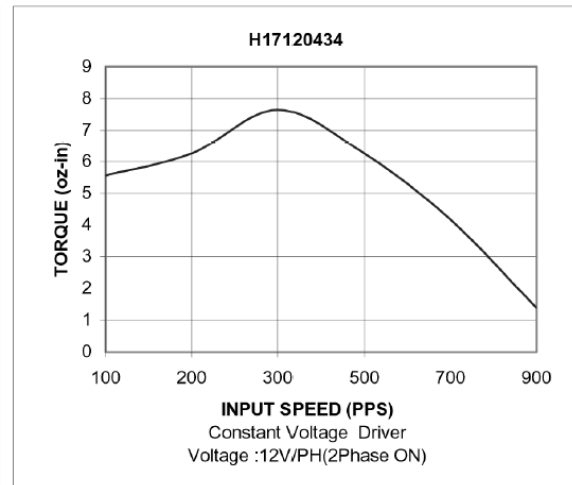
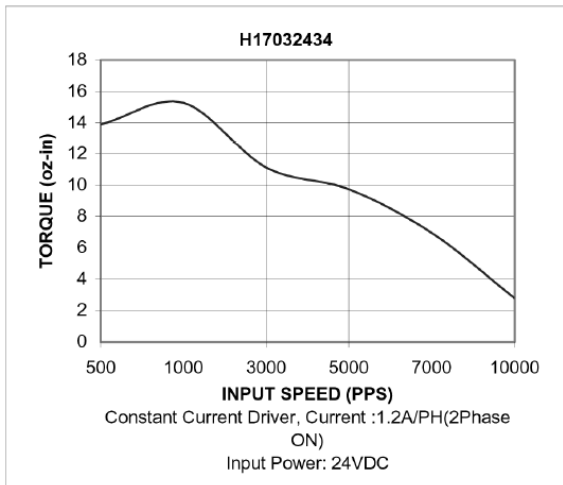
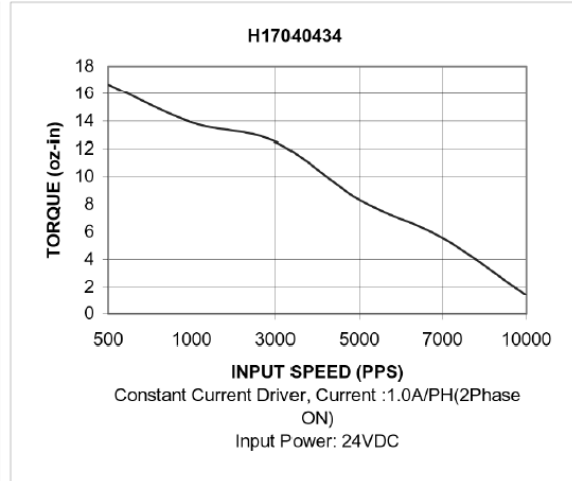
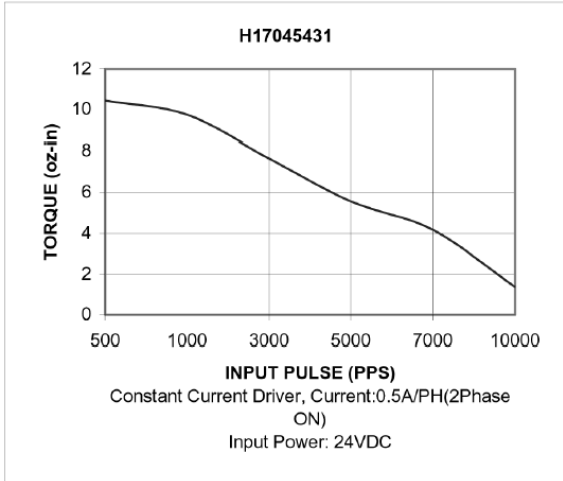

*Note: Typical Performance Data generated using full step, uni-polar controller with parallel connector

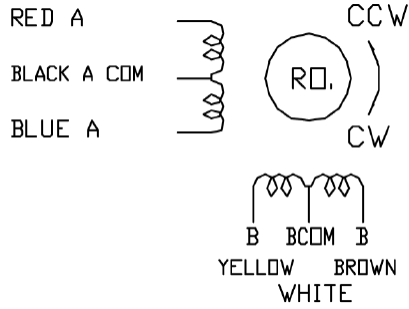

Full Step (2 Phase)				
CW Rotation viewing Mounting End				
Step	A (Red)	B (Yellow)	/A (Blue)	/B (Brown)
0	On	On		
1		On	On	
2			On	On
3	On			On
4	On	On		