

SYNCHRONOUS MOTOR FAMILY

Series GA Reversible Hysteresis Synchronous Motor

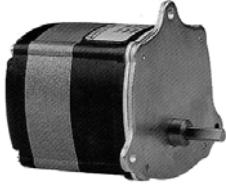

GA Series motors provide a high torque rating of 600 oz-in [4237 mN-m] at 1 RPM. A choice of 14 different speeds, from 1 RPM to 300 RPM, are available for operation at 115 VAC at 60 Hz. High quality construction throughout assures dependable field performance.

Gear trains for GA motors are rated for loads of up to 600 oz-in [4237 mN-m]. The selection of materials and the design of each gear in the GA Series gear train is based on its position in the reduction sequence. This provides optimum performance for the unique speed and loading of each gear and overall balance of all components in the gear assembly. Models listed are designed for 115V, 60 Hz operation. A capacitor is required for operation.

| Model | Part Number | Speed @ Output Shaft (rpm) | Rated Pull-Out Torque (mN-m) | Rated Pull-Out Torque (oz-in) | Input Power (watts) | Capacitor Value (MFD) | Temp. Rise °C. Full Load | Weight (g) | Weight (oz) |
|-------|-------------|----------------------------|------------------------------|-------------------------------|---------------------|-----------------------|--------------------------|------------|-------------|
| GA | 992093 | 1 | 4237 | 600 | 10 | 1.0 | 50 | 1134 | 40 |
| GA | 992094 | 2 | 2118 | 300 | 10 | 1.0 | 50 | 1134 | 40 |
| GA | 992110 | 3 | 1412 | 200 | 10 | 1.0 | 50 | 1134 | 40 |
| GA | 992095 | 4 | 1059 | 150 | 10 | 1.0 | 50 | 1134 | 40 |
| GA | 992112 | 5 | 847 | 120 | 10 | 1.0 | 50 | 1134 | 40 |
| GA | 992096 | 6 | 706 | 100 | 10 | 1.0 | 50 | 1134 | 40 |
| GA | 992097 | 10 | 423.7 | 60 | 10 | 1.0 | 50 | 1134 | 40 |
| GA | 992106 | 18 | 235.4 | 33.33 | 10 | 1.0 | 50 | 1134 | 40 |
| GA | 992098 | 30 | 141.2 | 20 | 10 | 1.0 | 50 | 1134 | 40 |
| GA | 992099 | 60 | 70.6 | 10 | 10 | 1.0 | 50 | 1134 | 40 |
| GA | 992108 | 100 | 42.4 | 6 | 10 | 1.0 | 50 | 1134 | 40 |
| GA | 992100 | 120 | 35.3 | 5 | 10 | 1.0 | 50 | 1134 | 40 |
| GA | 992109 | 150 | 28.2 | 4 | 10 | 1.0 | 50 | 1134 | 40 |
| GA | 992105 | 300 | 14.1 | 2 | 10 | 1.0 | 50 | 1134 | 40 |

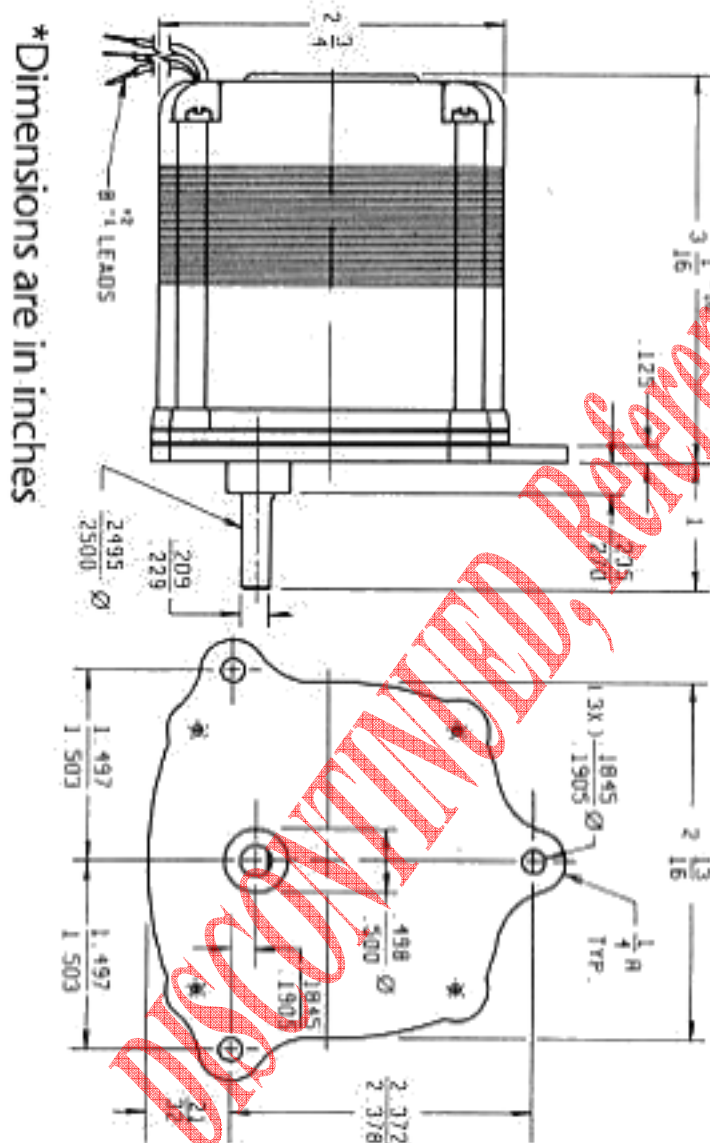

UNCONTROLLED REFERENCE ONLY

